



General Certificate of Education  
Advanced Level Examination  
June 2013

## Physics

**PHA6/B6/XTN**

(Specifications A and B)

Unit 6      Investigative and Practical Skills in A2 Physics  
Route X Externally Marked Practical Assignment (EMPA)

## Instructions to Supervisors Confidential

To be given immediately to the teacher(s) responsible for GCE Physics

Open on receipt

- These instructions are provided to enable centres to make appropriate arrangements for the Unit 6 Externally Marked Practical Assignment (EMPA)
- It is the responsibility of the Examinations Officer to ensure that these *Instructions to Supervisors* are given immediately to the Supervisor of the practical examination.

---

## INSTRUCTIONS TO THE SUPERVISOR OF THE EXTERNALLY MARKED PRACTICAL EXAMINATION

### General

#### Security/confidentiality

The instructions and details of the EMPA materials are strictly confidential. In no circumstances should information concerning apparatus or materials be given before the examination to a candidate or other unauthorised person.

The EMPA supplied by AQA at AS and at A2 for a given academic year must only be used in that academic year. It may be used for practice in later academic years.

Using information for any purpose beyond that permitted in this document is potentially malpractice. Guidance on malpractice is contained in the JCQ document *Suspected Malpractice in Examinations and Assessments: Policies and Procedures*.

The Examinations Officer should give copies of the Teacher Notes (PHA3/B3/XTN and/or PHA6/B6/XTN) to the teacher entrusted with the preparation of the examination upon receipt.

#### Material from AQA

For each EMPA, AQA will provide:

- *Instructions to Supervisors*
- Section A Task 1 and Task 2 question paper/answer booklets
- Section B EMPA written test papers.

#### Preparation/Centre responsibility

This practical assessment should be carried out after candidates have acquired the necessary skills and after the appropriate sections of the specification have been taught so that candidates are familiar with any specialist apparatus involved.

The assessment must be carried out between the dates specified by AQA.

It is the responsibility of the centre to ensure that each of the specified practical activities works with the materials provided to the candidates.

**The assessment and management of risks are the responsibility of the centre.**

#### Practical Skills Verification (PSV)

Candidates must undertake the five practical activities specified, in order for them to demonstrate in the EMPA that they can use apparatus appropriate to the teaching of Physics at this level. In doing so, candidates will be familiar with the equipment and skills they will use in the EMPA. The teacher must confirm that this requirement has been met on the front cover of the Section B written paper.

---

## Section A: Task 1 and Task 2

- Candidates should work individually and be supervised throughout. They should not discuss their work with other candidates at any stage.
- The work can be carried out in normal timetabled lessons and at a time convenient to the centre. Teachers will be in the best position to judge how many sessions are appropriate for candidates in their own centre.
- The candidates' work must be handed to the teacher at the end of each practical session and kept securely until the next stage of assessment.
- There is no specified time limit for these tasks, however candidates should be informed by the Supervisor of the expected timescale and timetable arrangements involved in carrying out the EMPA. Candidates must also be instructed that all readings must be entered in the question paper/answer booklet provided and all working must be shown. **Scrap paper must not be used.**

### Sharing equipment / working in groups

Candidates are to work individually. Where resources mean that equipment has to be shared, the teacher should ensure that the candidates complete the tasks individually. Where appropriate, spare sets of apparatus should be prepared to ensure that time is not lost due to any failure of equipment.

Centres may choose to provide sufficient sets of apparatus for the candidates to work on Section A in a circus format with some candidates completing the questions in reverse order. In such cases the changeover should be carefully supervised and the apparatus returned to its original state before being used again.

### Practical sessions

Before the start of the test the apparatus and materials for each candidate should be arranged, ready for use, on the bench. The apparatus should not be assembled unless a specific instruction to do so is made in these Instructions.

If a candidate is unable to perform any experiment, or is performing an experiment incorrectly, or is carrying out some unsafe procedure, the supervisor is expected to give the minimum help required to enable the candidate to proceed. In such instances the *Supervisor's Report* should be completed with the candidate's name and number, reporting to the Examiner the nature and extent of the assistance given. No help may be given to proceed with the analysis of their experimental data.

Any failure of equipment which, in the opinion of the Supervisor, may have disadvantaged any candidate should be detailed on the *Supervisor's Report*.

Turn over ►

---

## Section B: EMPA written test

- The Section B EMPA written test should be taken as soon as convenient after completion of Section A.
- This test must be carried out under supervision and must be completed in a single uninterrupted session.
- When carrying out the Section B EMPA written test, candidates should be provided with their completed copy of Section A task 2 question paper/answer booklet.
- Supervisors should ensure that candidates understand that Section A task 2 is for reference only and they must not make any written alterations to this previous work while undertaking Section B.
- The duration of the Section B EMPA written test is 1 hour 15 minutes except where candidates have been granted additional time or rest breaks.

### Administration

Candidates must not bring any paper-based materials into any session or take any assessment materials away at the end of a session. Electronic and communication devices, including mobile telephones, iPods, MP3 players are **not** allowed.

### Modifications

The equipment requirements for the experimental tasks are indicated in these Instructions. Centres are at liberty to make any reasonable minor modifications to the apparatus which may be required for the successful working of the experiment but it is advisable to discuss these with the Assessment Adviser or with AQA. A written explanation of any such modification must be given in the *Supervisor's Report*.

### Absent candidates

Candidates absent for any part of Section A should be given an opportunity to carry out the practical exercises before attempting the Section B EMPA written test. No credit can be given for any analysis done when evidence of the relevant practical work is not provided.

### Redrafting

Candidates may make only one attempt at a particular EMPA and redrafting is **not** permitted at any stage, during the EMPA.

### The Supervisor's Report

The *Supervisor's Report* provided in this document should be sent to the Examiner with the scripts. Details should be given on the *Supervisor's Report* if

- any part of the equipment provided differs significantly from that specified in these Instructions
- any help is given to candidates in the event of any failure of or difficulties with the equipment.

Supervisors must also include any numerical data that is specified in the Instructions. This may involve the Supervisor performing an experiment before the test and collecting certain data. Such data should be given to the uncertainty indicated. Note that the Examiners may rely heavily on such data in order to make a fair assessment of a candidate's work.

### **Security of assignments**

Candidates' scripts and any other relevant materials, printed or otherwise, should be collected and removed to a secure location at the end of each session. Under no circumstances should candidates be allowed to remove question papers from the examination room.

Completed EMPAs are to be treated in the same manner as other completed scripts and should be kept under secure conditions before their despatch to the Examiner.

Candidates must **not** be given access to their completed 'live' EMPA. Discussion of 'live' EMPA materials is not permitted.

### **Submission of materials to the AQA Examiner**

Once completed, each candidate's completed EMPA should be collated in candidate number order and in the following order

- Section A task 1
- Section A task 2
- Section B EMPA written test.

The assembled material should then be secured using a treasury tag. A copy of the Supervisor's Report should be sent with the scripts.

**For Section A Task 1, Question 1**

Candidates are to perform two experiments involving the vertical oscillations of a spring-mass system.

**Apparatus required for first experiment:**

- 2 retort stands, each fitted with a boss and a clamp; one is to support the spring-mass systems and the other to hold the vertical ruler
- digital stopwatch capable of reading to 0.1 s or 0.01 s
- some method of making a fiducial mark, at the discretion of the centre, eg 'Post-It' label with a pencil mark ruled across at the median line that can be affixed to the vertical ruler
- 1 expendable steel spring; if new springs are to be used these should be briefly placed under tension (eg of about 5 N) before use
- wooden metre ruler, as straight as possible; this is to be clamped vertically alongside the spring-mass system with the zero graduation at the top, the positioning should enable the reading of  $r_1$  and  $r_2$  to be made (see diagram below)
- set square or plane mirror to eliminate parallax error when making the reading of  $r_1$  and  $r_2$
- mass hanger and slotted masses to give total mass = 200 g; this arrangement should be taped together and labelled 'mass  $M_1$ '
- further slotted masses to give total mass = 200 g, this arrangement to be taped together and labelled 'mass  $M_2$ '; it should be possible for this mass to be added to  $M_1$  to give a combined mass ( $M_1 + M_2$ ).

Set up the vertical ruler alongside the clamped spring ensuring the zero graduation is at the top, as shown in the left-hand view in the diagram below.

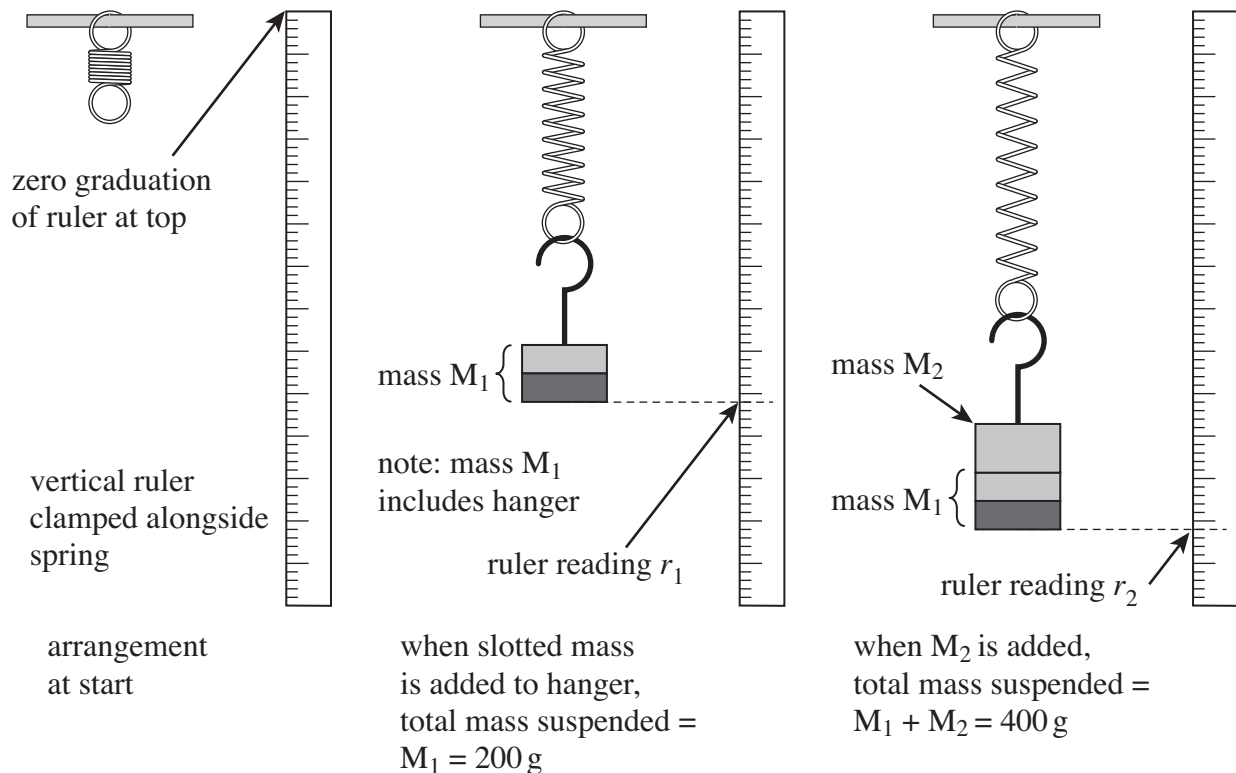

Ensure that the positioning of the ruler is such that the readings  $r_1$  and  $r_2$  can be made when firstly  $M_1$  is added and then  $M_2$  is also added.

Place the fiducial mark in clear view for the candidate to use.

When they have completed part (c) of the question, candidates will disassemble the apparatus to use in the second experiment, part (d) (see page 7).

To avoid confusion as candidates move to this second experiment, Supervisors should remove masses  $M_1$  and  $M_2$  and the spring used in the first experiment and provide, on request, the additional apparatus detailed on page 7.

**Apparatus required for second experiment:****As used in the first experiment**

- 2 retort stands, each fitted with a boss and a clamp
- digital stopwatch capable of reading to 0.1 s or 0.01 s
- wooden metre ruler, as straight as possible.

**Additional equipment:**

- mass hanger and slotted masses to give total mass = 500 g; this arrangement should be taped together and labelled 'mass  $M_3$ '
- mass hanger and slotted masses to give total mass = 500 g; this arrangement should be taped together and labelled 'mass  $M_4$ '
- 2 expendable steel springs; a loop of string is to be tied at one end of each spring so that these can be suspended from the metre ruler (see note on page 6 about new springs)
- Blu-Tack or similar
- large mass or G-clamp to stabilise the arrangement, if the need arises.

The candidates will arrange the apparatus as shown below.

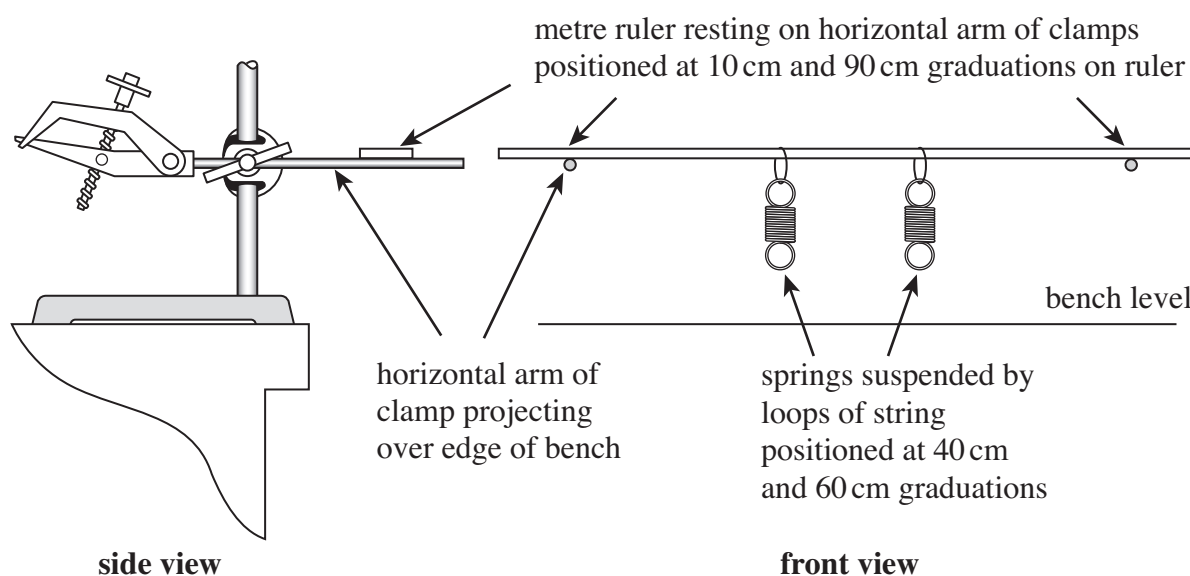

The metre ruler is supported on the horizontal arms of the clamps which will project over the edge of the bench. The masses  $M_3$  and  $M_4$  will be suspended from the lower ends of the springs which the candidates will have attached to the ruler using loops of string.

A means of making the experiment stable, eg large mass or G-clamp, should be provided if the need arises.

**Before the experiment, for each set of apparatus, set the masses in vertical oscillation so that the periods can be compared; use the Blu-Tack to make any slight adjustment necessary to make these periods the same.**

**Supervisors should alert the candidates to the presence of any Blu-Tack and warn them not to remove it.**

This apparatus should be returned to its original state (ie for Experiment 1) for any candidate following on.

**Examiners require the following information.**

The typical time for the energy of  $M_3$  to transfer to  $M_4$  and then back again, to  $\pm 2$  s.

**Turn over ►**

**For Section A Task 1, Question 2**

Candidates will investigate how the magnetic flux density varies between two bar magnets.

**Apparatus required:**

- 2 good quality rectangular bar magnets; these should be of approximately equal strength and have some indication of polarity (the ALNICO type, of dimensions  $50 \times 15 \times 10$  mm, have a dimple at the north-seeking end)
- plotting compass with two transparent faces; check that the direction indicated by these has not been reversed
- wooden metre ruler, as straight as possible
- wooden half-metre ruler, as straight as possible
- set square
- 300 mm plastic ruler for graph drawing
- masking tape or Sellotape so that, once aligned by the candidate, the rulers can be stuck down to the bench (or drawing board if that arrangement is used).

Dual scales on the rulers may lead to confusion (see **Figure 2** of the question/answer booklet); Supervisors may wish to tape over one scale.

Check that there is sufficient bench space for the candidates to perform this experiment; note that the candidates will require the half-metre ruler to point away from them.

Check also that the presence of under-bench service pipes does not significantly affect the direction in which the plotting compass points. It is suggested that the rulers are laid out as shown below with a sheet of A3 paper (shown shaded) placed below. Providing that the compass does not deviate by more than  $10^\circ$  from north when positioned at any point on the paper then the arrangement will be satisfactory.

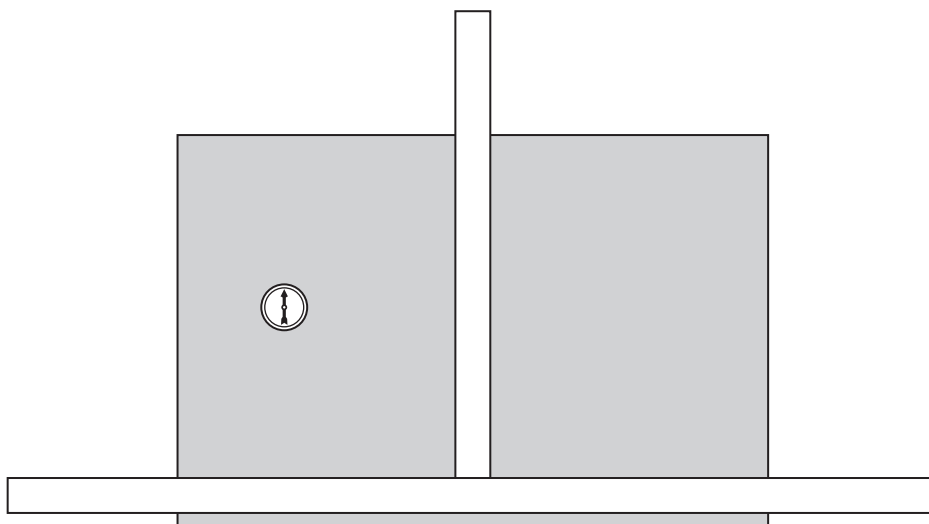

If bench space is limited or unsatisfactory the experiment can be performed on a drawing board positioned on a stool.

Place all apparatus required on the bench before the experiment, keeping the compass away from the magnets in case the compass becomes reverse-magnetised.

**It should be explained to candidates meeting these magnets for the first time how they should identify the north-seeking pole.**

**Examiners require no further information.**



### For Section A Task 2

Candidates are to investigate the torsional oscillation of a magnet suspended in a field produced between the poles of two further magnets, as the separation of these magnets is varied.

#### Apparatus required for each candidate:

- 3 good quality rectangular bar magnets of the same type as used in Section A Task 1, Question 2
- about half a metre of thread or thin string
- retort stand fitted with boss and clamp; wooden stands are preferable, but as long as the base or rod of any metal stand does not interfere with the motion of the suspended magnet, then these are acceptable
- digital stopwatch capable of reading to 0.1 s or 0.01 s
- wooden metre ruler, as straight as possible
- thick copper wire or similar (22 SWG or thicker) to fashion the stirrup that supports the suspended magnet
- Blu-Tack for packing below the two magnets placed on the metre ruler

Fashion the stirrup that enables a magnet to be suspended with the longest edges parallel to the bench and the largest faces parallel to the bench. A suggested arrangement is shown below.

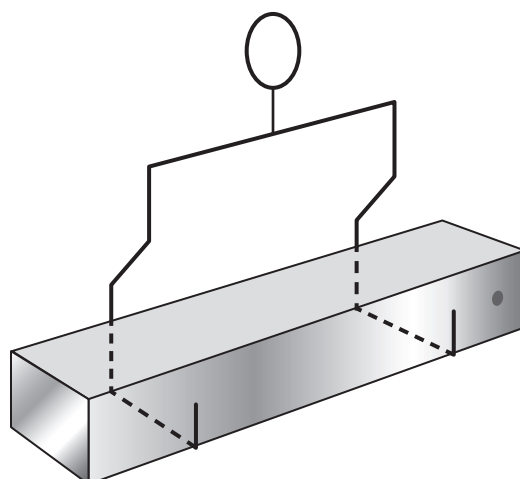

Attach about 40 cm of thread to the stirrup and suspend the magnet so that it is parallel to, and about 2 cm above, the bench.

Before the examination, the Supervisor should locate a suitable position for the stand from which the stirrup is suspended; there should be sufficient space for the metre ruler, with the graduated face uppermost, to be positioned on the bench below the stirrup, as shown in **Figure 5a** in the question/answer booklet.

The centre of the metre ruler should be directly below the suspended magnet and it should be possible for the candidate to align the ruler with the long axis of the magnet.

Once a suitable position for the stand has been determined, the base of the stand should be taped to the bench.

Sufficient working space should be provided to enable candidates to place the metre ruler on the bench with its centre directly below the suspended magnet. Candidates will be instructed to rotate the ruler about its mid-point until it is aligned with the long axis of the suspended magnet.

**Examiners require no information for this question.**

Turn over ►



**Section A Task 1**

Follow the instructions given below.

Give the information required in the spaces provided.

No descriptions of the experiments are required.

- 1** You are to perform two experiments involving the vertical oscillations of a spring-mass system.
- 1 (a)** You are provided with a retort stand fitted with a clamp from which a spring is suspended. A metre ruler has been clamped vertically alongside the spring.  
**Do not adjust the positions of the clamps to which the spring and the metre ruler are attached.**
- You are also provided with masses labelled  $M_1$  and  $M_2$ .
- 1 (a) (i)** Attach  $M_1$  to the lower end of the spring.  
Record  $r_1$ , the metre ruler reading which is at the same horizontal level as the bottom of  $M_1$  when  $M_1$  is in equilibrium.
- 1 (a) (ii)** Displace and then release  $M_1$  so that it performs small amplitude vertical oscillations.  
Make suitable measurements to determine  $T_1$ , the time period of the oscillations.  
A fiducial mark has been provided for your use.
- 1 (a) (iii)** Add  $M_2$  to the mass already on the spring.  
Record  $r_2$ , the metre ruler reading which is at the same horizontal level as the bottom of  $M_1$  when in equilibrium.
- 1 (a) (iv)** Displace and then release the mass on the spring and make suitable measurements to determine  $T_2$ , the time period of the oscillations.

Turn over ►

- 1 (b) Evaluate  $\frac{r_2 - r_1}{(T_2 - T_1)(T_2 + T_1)}$
- 1 (c) Explain how you reduced uncertainty in your readings of  $r_1$  and  $r_2$ .  
You may use a sketch to illustrate your answer.

Teacher use only



With  $M_4$  held at rest at the equilibrium position, displace  $M_3$  vertically downwards through approximately 5 cm.

Release both masses simultaneously so that  $M_3$  performs small-amplitude vertical oscillations.

- 1 (d) (i) Observe and describe the subsequent motions of  $M_3$  and  $M_4$ , with particular reference to the amplitude variations and phase relationship between the motions of the masses.
- 1 (d) (ii) Make suitable measurements to determine  $\tau$ , the time for the energy of  $M_3$  to transfer to  $M_4$  and then back again.

Teacher use only

- 2 You are to investigate how the magnetic flux density varies between two bar magnets. You are provided with a metre ruler and a half-metre ruler. Place the rulers with their largest faces in contact with the bench then use the compass, together with the set-square, to position the rulers with the alignment shown in **Figure 2**.

Figure 2

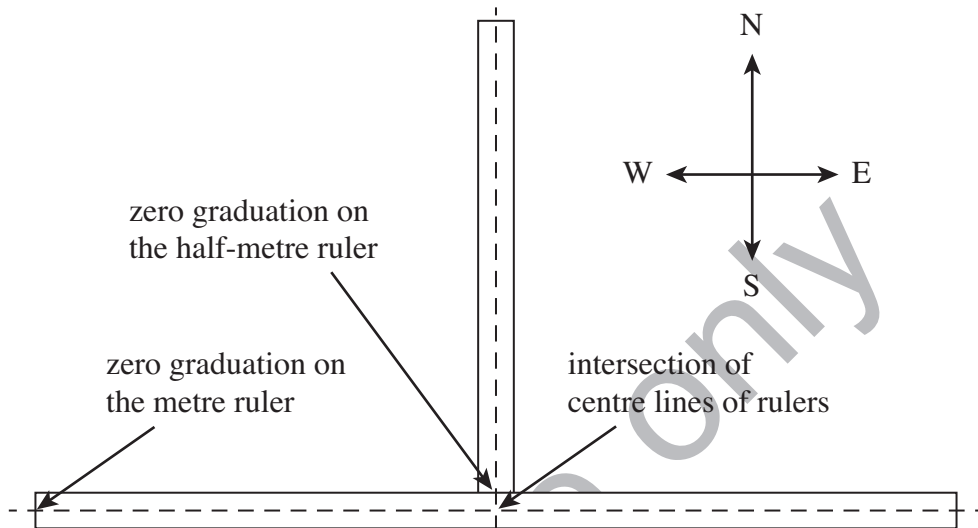

Place the compass at the intersection of the centre line of the rulers. Make any further small adjustment to the direction of the rulers that may be necessary so that the needle is aligned with the centre line of the half-metre ruler.

**Once in position the rulers should be taped to the bench.**

Place a bar magnet on the metre ruler with the north-seeking pole at approximately the 400 mm graduation. The north-seeking pole of this magnet should point eastwards. The magnet should be aligned with the centre line of the metre ruler, as shown in

**Figure 3.**

Figure 3

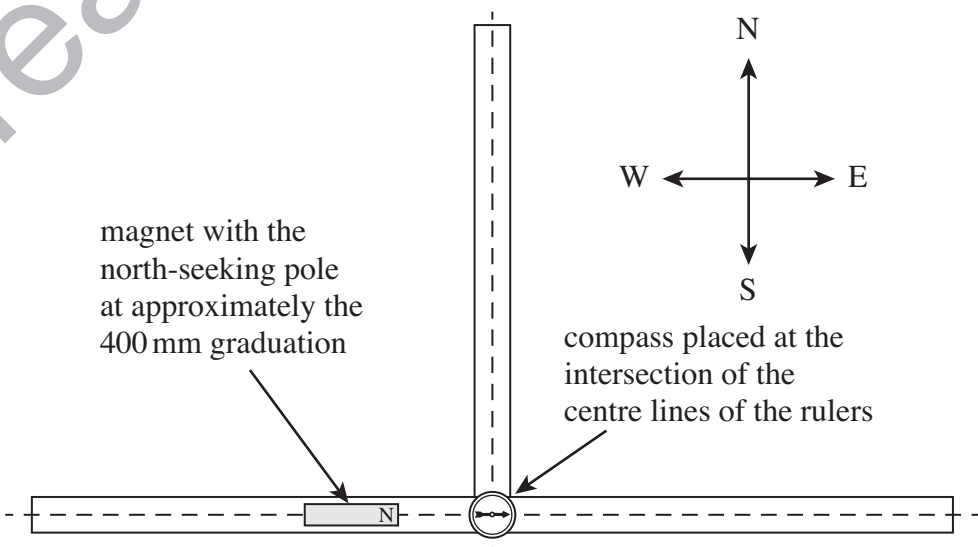

Turn over ►

Place the other bar magnet at about the mid-point of the half-metre ruler with the north-seeking pole of the magnet pointing eastwards. The centre of this magnet should lie directly above the centre line of the half-metre ruler.

Move this magnet directly towards the compass until the needle points due north again.

- 2 (a) (i) Measure and record in **Table 1** below, the distances  $x$  and  $y_1$  defined in **Figure 4**.

**Figure 4**

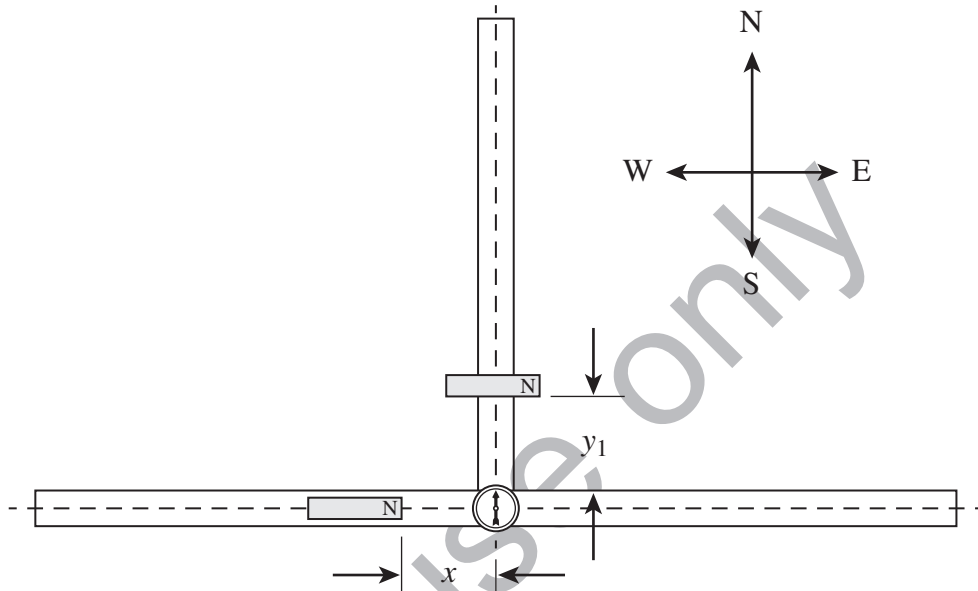

- 2 (a) (ii) Maintaining their orientation, interchange the positions of the two magnets. **With the same  $x$  value as before**, adjust the position of the other magnet until the compass once again points due north. Measure and record in **Table 1**  $y_2$ , the distance corresponding to  $y_1$  in **Figure 4** when the magnets are interchanged.
- 2 (a) (iii) Calculate and record  $y$ , the mean value of the distances  $y_1$  and  $y_2$ .
- 2 (a) (iv) Repeat the procedure for three **larger** values of  $x$  to complete **Table 1**.

**Table 1**

$x/\text{mm}$	$y_1/\text{mm}$	$y_2/\text{mm}$	$y/\text{mm}$



- 2 (b) Add suitable scales to the grid below and plot a graph to show how  $y$  varies with  $x$ .

$y/\text{mm}$

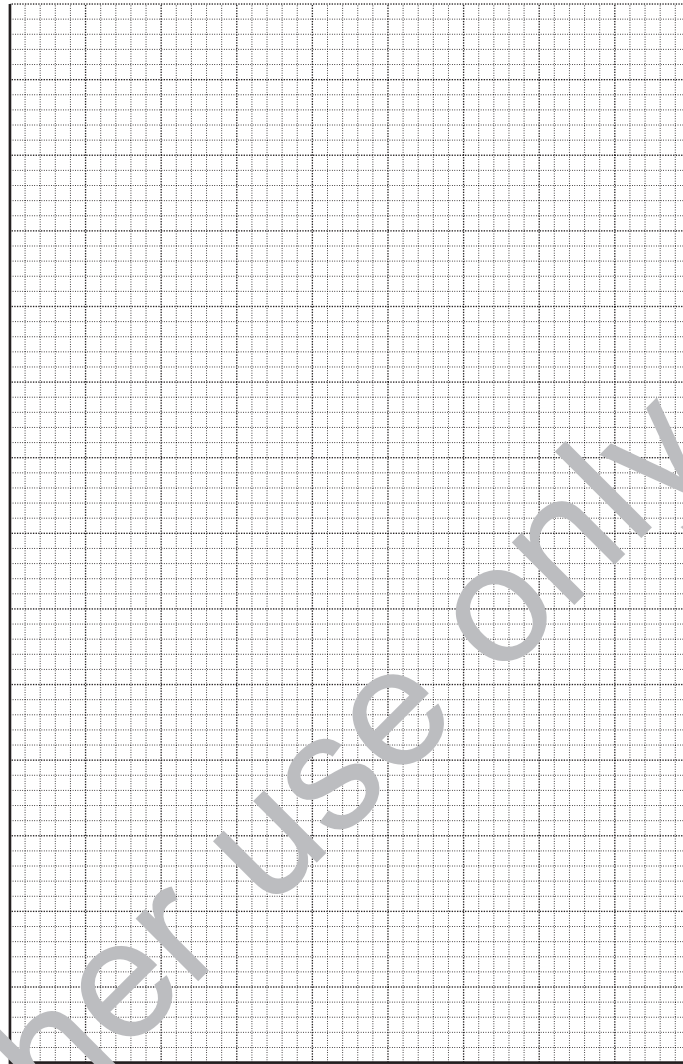

$x/\text{mm}$

- 2 (c) Determine the gradient,  $G$ , of your graph.

Turn over ►

### Section A Task 2

Follow the instructions given below.

Give the information required in the spaces provided.

No description of the experiment is required.

- 1** In this experiment you are to investigate the oscillation of a bar magnet suspended in a magnetic field of variable magnetic flux density.

You are provided with a bar magnet, supported in a stirrup suspended from a retort stand. Do not remove the stand or adjust the height of the clamp to which the stirrup is attached. Place the metre ruler on the bench with the graduated face uppermost and the centre of the magnet directly above the 50 cm graduation on the ruler.

Turn the metre ruler about its mid-point until it is aligned with the long axis of magnet A, as shown in **Figure 5a**.

Keeping the largest surface of the magnet uppermost, the long axis of the magnet parallel to the bench and the thread supporting the magnet vertical, displace each end of the magnet in opposite directions so the magnet is rotated through a small angle, as shown in **Figure 5b**.

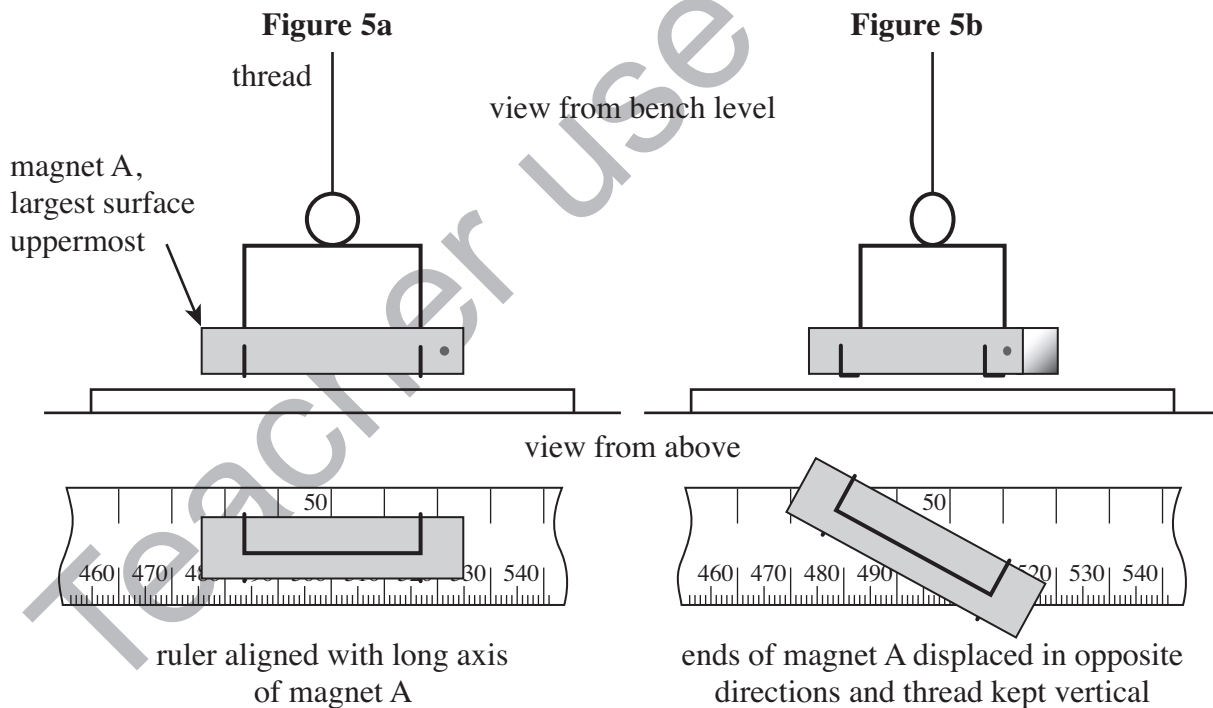

- 1 (a)** Simultaneously release both ends of magnet A so that it performs small-amplitude torsional oscillations. Make suitable measurements to determine  $T_0$ , the period of these oscillations.

- 1 (b) Position magnets B and C on the ruler, so that each attracts the nearest pole of magnet A. Use Blu-Tack below magnets B and C until all three magnets lie approximately in the same horizontal plane with their largest faces uppermost. Do not alter the length of the thread supporting magnet A.

Adjust the positions of magnets B and C until they are equidistant from the nearer ends of magnet A, and the separation,  $d$ , is between 50 cm and 60 cm, as shown in **Figure 6**, which is not to scale.

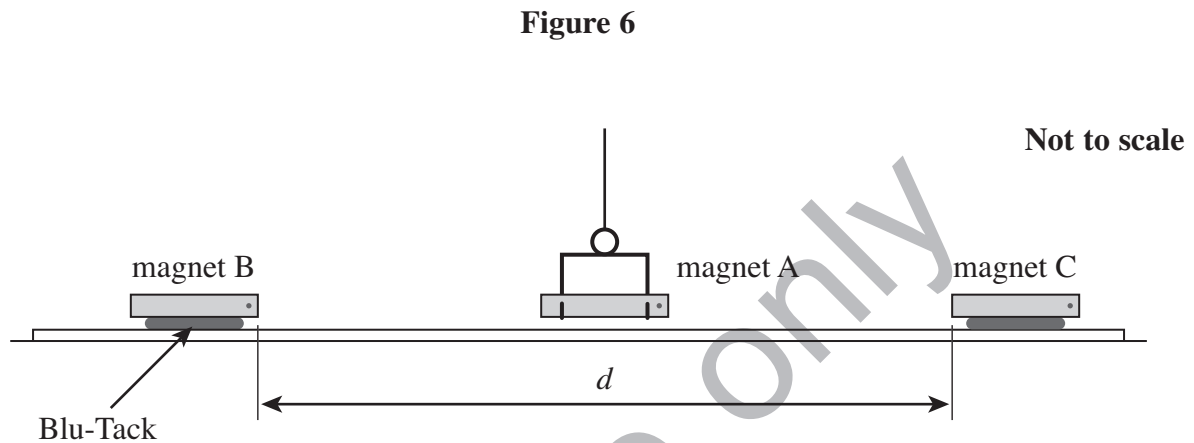

Displace magnet A as before, then release it so that it performs small-amplitude torsional oscillations.

Measure and record the period,  $T$ , of these oscillations, then repeat the procedure for **four smaller** values of  $d$ : **do not** use values of  $d$  less than 25 cm.

Record your measurements below.

Note that the independent variable should be recorded in the **left-hand** column of your table.

- 1 (c)** Plot, on the grid opposite, a graph with  $\log\left(\left(\frac{1}{T^2} - \frac{1}{T_0^2}\right)/\text{s}^{-2}\right)$  on the vertical axis and  $\log(d/\text{cm})$  on the horizontal axis.

Tabulate below the data you will plot on your graph.

Teacher use only

**Section B**

Answer **all** the questions in the spaces provided. Time allowed 1 hour 15 minutes.

You will need to refer to the work you did in Section A Task 2 when answering these questions.

**1 (a)** Determine the gradient,  $G$ , of your graph of  $\log \left( \frac{1}{T^2} - \frac{1}{T_0^2} \right)$  against  $\log d$ .

**1 (b)** It is suggested that the period is related to the distance by the expression

$$\frac{1}{T^2} - \frac{1}{T_0^2} = kd^n,$$

where  $k$  is a constant and  $n$  is an integer.

**1 (b) (i)** Deduce the value of  $n$ .

**1 (b) (ii)** Deduce the unit for  $k$ .

**1 (b) (iii)** State and explain how you could use your graph to deduce the numerical value of  $k$ .

Teacher use only

Turn over ►

- 2 In Section A Task 1 you observed the energy transfer between masses  $M_3$  and  $M_4$  suspended by springs from a horizontal metre ruler using the apparatus shown in **Figure 7**.

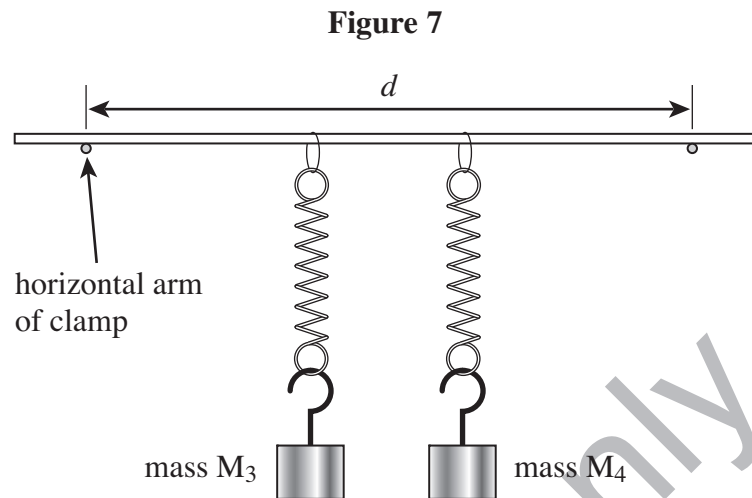

With the same apparatus, a student investigates how  $d$ , the horizontal distance between the arms of the clamps on which the metre ruler is supported, affects  $\tau$ , the time of energy transfer between  $M_3$  and  $M_4$ .

The student measured the times for  $n$  energy transfers between the masses, as shown in **Table 2**.

**Table 2**

$d/\text{cm}$	$n$	$n\tau/\text{s}$	$n\tau/\text{s}$	$\tau/\text{s}$
86.0	6	212	209	
78.0	5	236	240	
70.0	6	408	*	
65.0	4	347	*	

\* only one set of readings of  $n\tau$  was completed for these values of  $d$

- 2 (a) (i) Complete **Table 2** to show the values for  $\tau$  that the student obtained.
- 2 (a) (ii) Justify the number of significant figures you have given for the values of  $\tau$ .

- 2 (b) The student claimed that these results showed that  $\tau$  was directly proportional to  $\frac{1}{d^2}$ .  
Analyse the data in **Table 2** to show whether the student's claim is correct.
- 2 (c) Suggest **three** valid control variables for the experiment.

Teacher use only

- 2 (d) In a different experiment to illustrate energy transfer between oscillators, three bar magnets are arranged as shown in **Figure 8**.

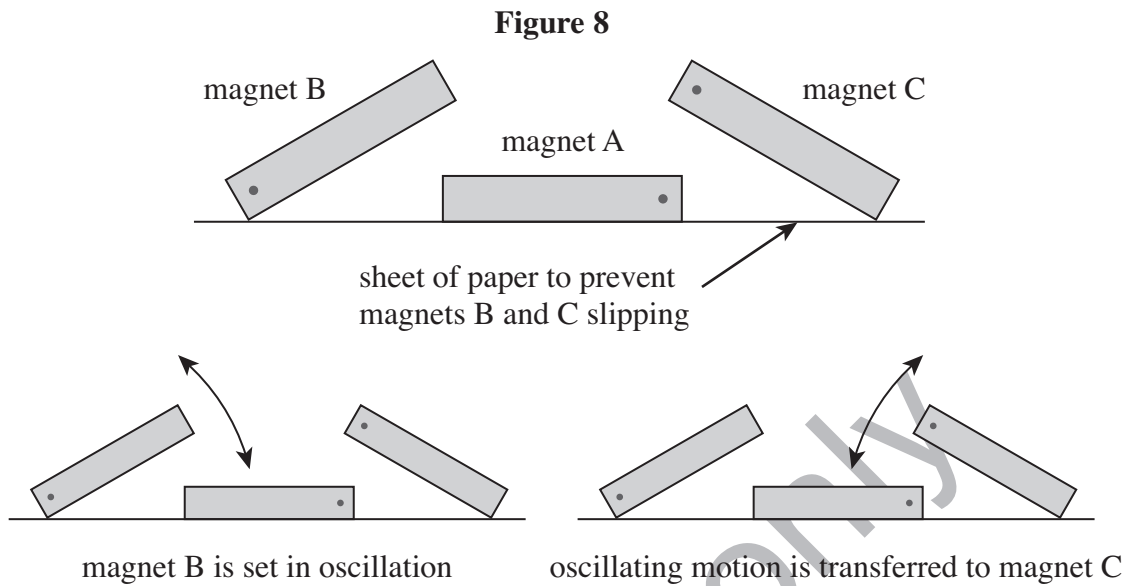

Magnets B and C are balanced on one edge using the repulsion produced by magnet A, the paper below providing friction to prevent B and C slipping.

When B is set oscillating about the point of contact with the paper, the oscillating motion is transferred within a few cycles to C, and then back again, as in your experiment with masses  $M_3$  and  $M_4$ .

A student uses a motion sensor and a data logger to record the motion of magnet B; the data are then exported to a computer and analysed using a spreadsheet.

**Figure 9** is based on 25000 measurements that are transferred to the data logger in 10 seconds and shows how the displacement,  $y$ , of the moving end of magnet B, varies with time,  $t$ .

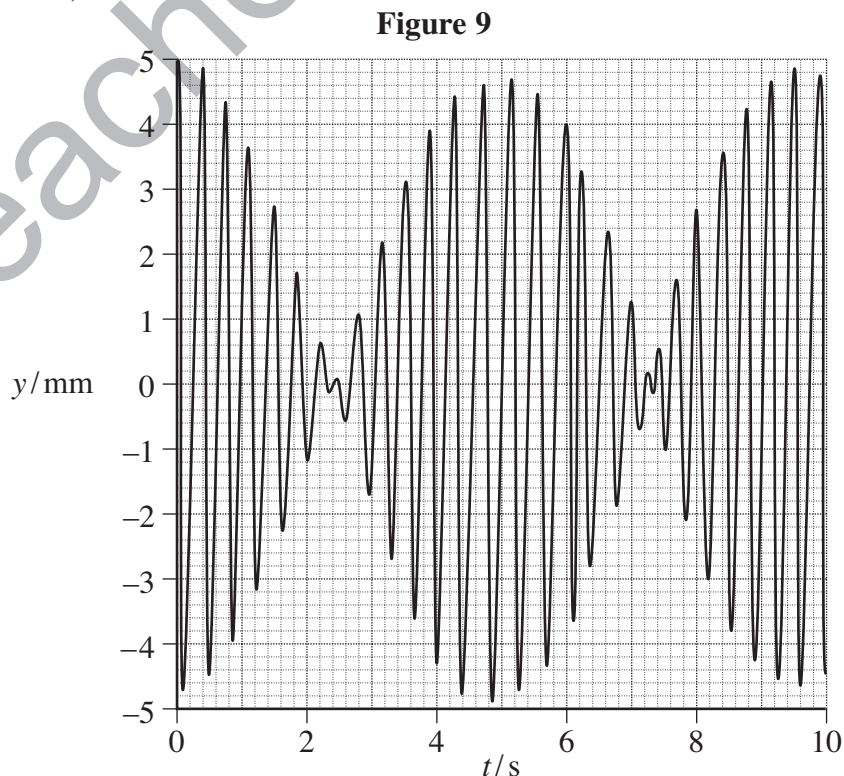



- 2 (d) (i) What was the *sample rate* of the data logger when the data displayed in **Figure 9** was being recorded?

The sample rate is then changed so that 25 000 measurements are transferred to the data logger in 250 seconds. These results are displayed in **Figure 10**.

**Figure 10**

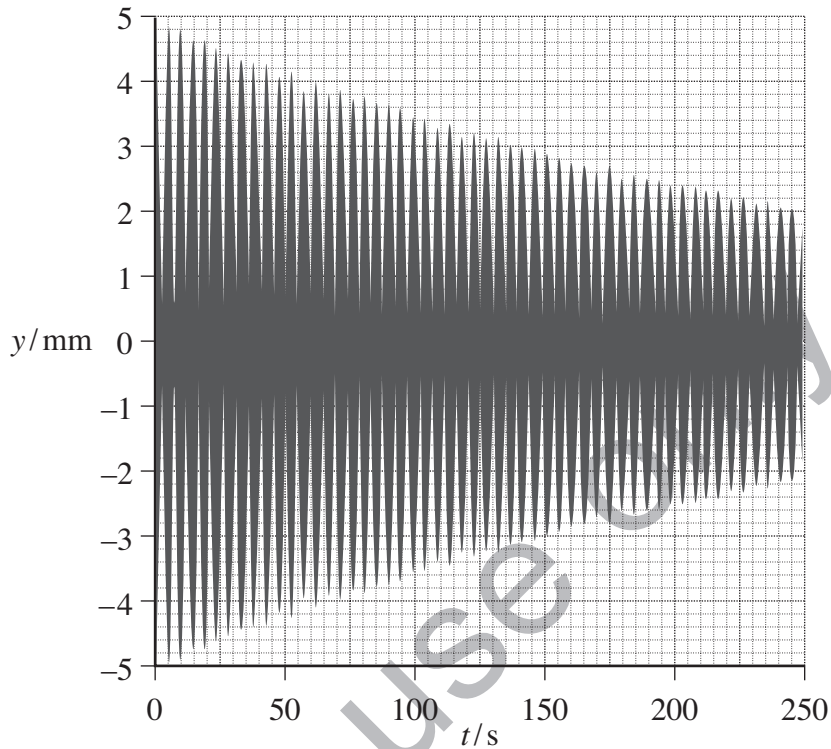

- 2 (d) (ii) If  $\tau$  = the time for energy transfer from magnet B to magnet C and back again to B, and  $T$  = the period of oscillations of magnet B, use **Figure 9** and **Figure 10** to determine  $\frac{\tau}{T}$ .  
You may assume that in both **Figure 9** and **10**,  $y$  has just reached a maximum value at  $t = 0$ .

- 3 In Section A Task 1 you used a compass to investigate how the magnetic flux density varies between two bar magnets. One magnet was positioned on a metre ruler, aligned east-west, and the other on a half-metre ruler, aligned north-south. A student, performing this experiment, sees that when the magnet on the half-metre ruler is removed the compass needle rotates through an angle  $\theta$ , as shown in **Figure 11**. The student notices that when the remaining magnet is moved along the metre ruler so that the distance  $x$  defined in **Figure 11**, is reduced,  $\theta$  increases.

**Figure 11**

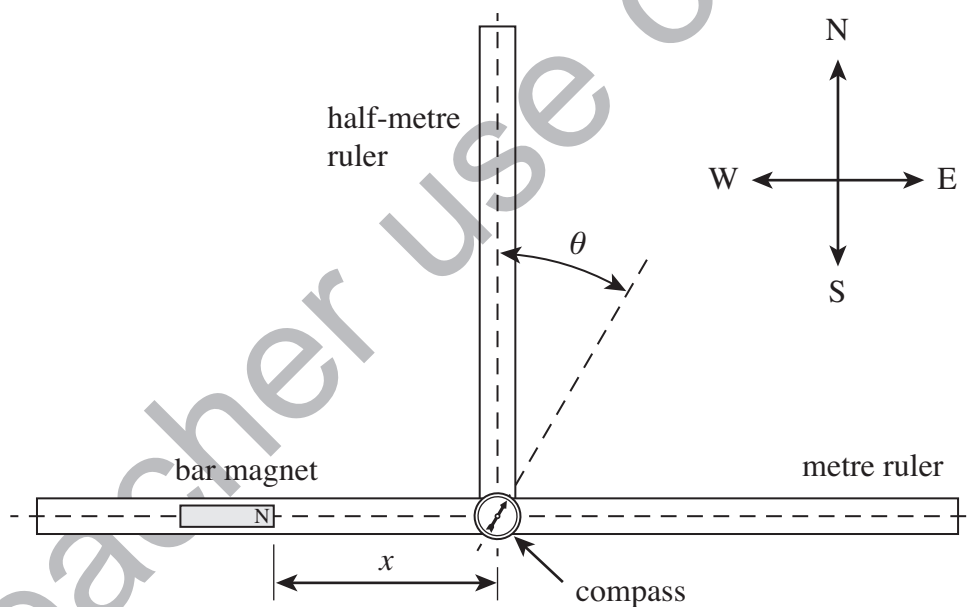

A teacher explains that  $B$ , the magnetic flux density due to the bar magnet at the plotting compass, is given by  $B = B_0 \tan \theta$ .

$B_0$  is the horizontal component of the ambient magnetic flux density (ie due to the surroundings) and is known to be  $1.8 \times 10^{-5}$  T.

- 3 (a) Describe how the student could investigate how  $B$  varies with  $x$ , the distance along the metre ruler from the end of the magnet to the centre of the compass.

Your answer should:

- explain how the student should make the necessary measurements to determine  $B$  and  $x$ ; you may wish to add detail to **Figure 11** to illustrate this part of your answer
- explain any relevant procedure that will reduce **systematic error** in the results for  $B$
- explain how the measurements will be used to determine how  $B$  varies with  $x$ .

Teacher use only

- 3 (b) The teacher shows the student an instrument called a deflection magnetometer and suggests that this could be used in place of the compass to reduce uncertainty in the measurement of  $\theta$ .

A deflection magnetometer, as seen from above, is shown in **Figure 12** and consists of a magnet pivoted at the centre of a rotary scale. A long pointer is mounted at right angles to the magnet and a mirror is set into the dial. A plotting compass is shown to the same scale so a comparison can be made with the size of the magnetometer.

**Figure 12**

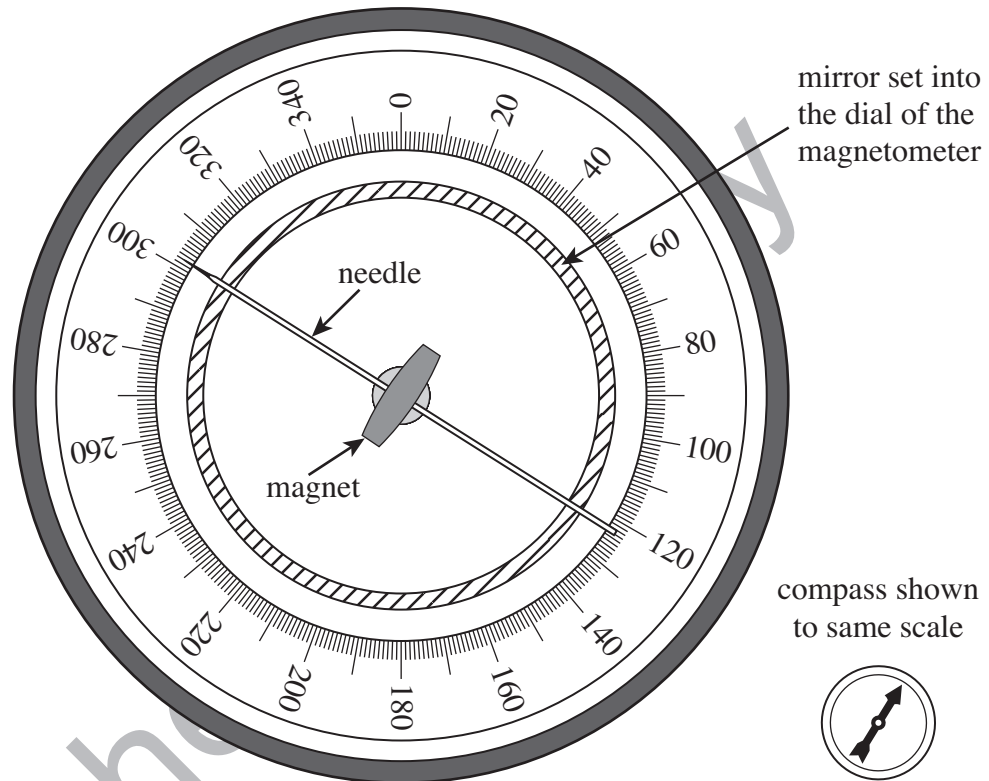

State and explain two features of the design of the magnetometer that help to reduce uncertainty in the measurement of  $\theta$ .